

VICUT

Tooling Expert

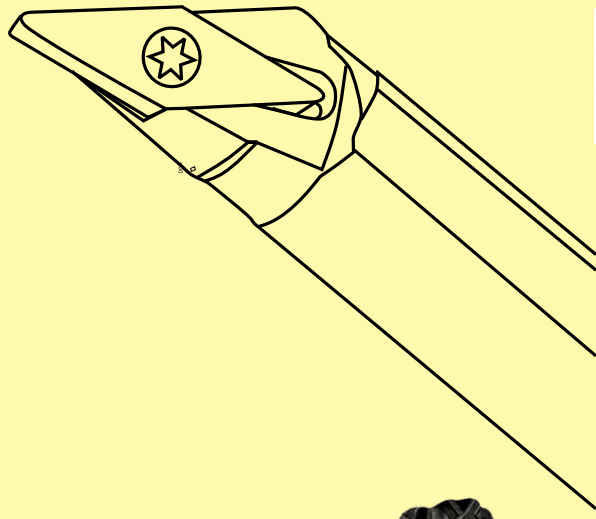
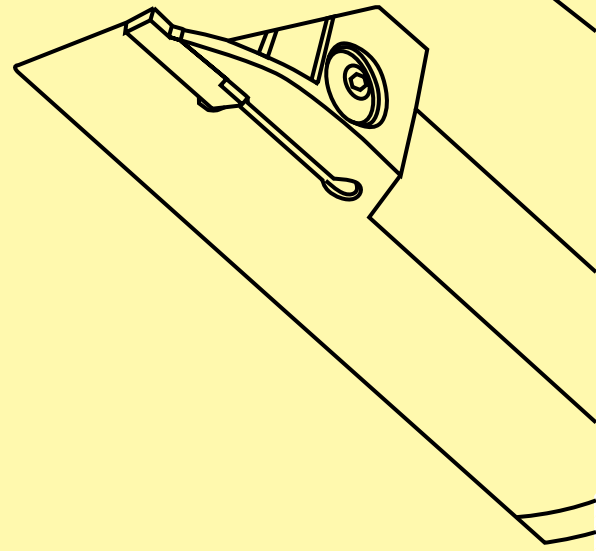
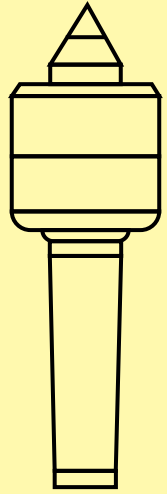
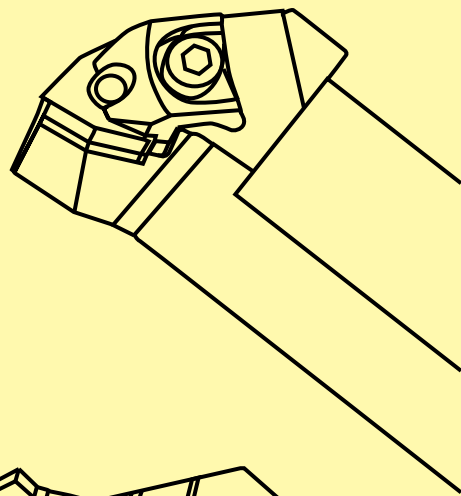
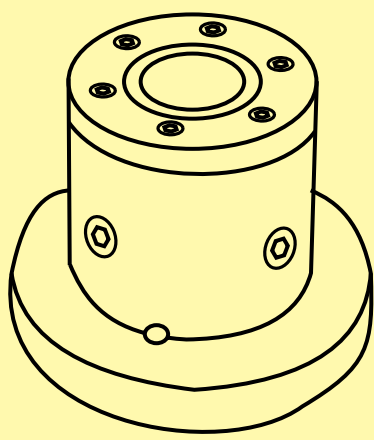

PRODUCT CATALOGUE

Chamfering End Mills

VCM 45°

TCMT 16 Tip



VCM 45° TC16-D5X23-
W20,16-L100-Z01

VCM 30°

TCMT 16 Tip



VCM 30° TC16-D6X23-
W20,16-L100-Z01

VCM 45°

TCMT 11 Tip



VMC45°TC11
D11x24-W-16
Z02

VCM 45°

TCMT 16 Tip



VCM 45° TC16-D1X18

VCM 45°

TCMT 16 Tip



VCM 45 TC16-D10X30/
W16/20-L100-Z02
VCM 45 TC16-D10X40/
W16/20-L100-Z02

VCM 45°

TCMT 16 Tip



VCM 45 Tc16-
D30X50
W16/20-L100-Z02

END MILLS

End Mills

TaeguTec AX0903 ISCAR APKT 1003 ZCC Tip



D16-2-C16-120,175,200
D18-2-C16-120,175,200
D20-2-C20-120,175,200
D20-3-C20-120,175,200
D25-2-C25-120,175,200
D25-3-C25-120,175,200
D32-3-C32-120,200,300

End Mills

SANDVIK R390-11 MITSUBISHI AP11, 16 AOMT10

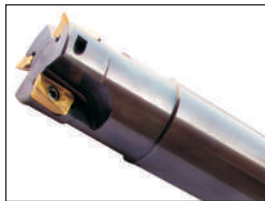

D16-2-C16-120,175,200
D18-2-C16-120,175,200
D20-2-C20-120,175,200
D20-3-C20-120,175,200
D25-2-C25-120,175,200
D25-3-C25-120,175,200
D32-3-C32-120,200,250

End Mills (Bull)

TaeguTec & MITSUBISHI Tip



VEMRC-RD1003-D20-
W20-150-Z02
TO
VEMRC-RD1204-D32-
C32-250-Z02
VEMRC-RD12T-D25/D40
W25/C32-L150(250)-Z02

U - Drill System

VTUM (WCM)

Tip Size :

16xD3 50 x 3D WCM



16 x D3 WCM 0302
19.5 x D3 WCM 0302
20 x D3 WCM 0402
23.5 x D3 WCM 0402
24 x D3 WCM 0503
29.5 x D3 WCM 0503
30 x D3 WCM 06T3
44 x D3 WCM 06T3
45 x D3 WCM 0804
50 x D3 WCM 0804

VTUM (SPMT)

KORLOY Tip

13 x 3D 25.5 x 3D SPMT



Tip Size :
12.5 x D3 SPMT 0502
15.5 x D3 SPMT 0502
16 x D3 SPMT 0602
21.5 x D3 SPMT 0602
22 x D3 SPMT 0702
25 x D3 SPMT 0702

VTUM (SP..)

TaeguTec Tip



25.5 x D3 50 x 3D SP..
Tip Size :
25.5 x D3 SP.. 07T3
27.5 x D3 SP.. 07T3
28 x D3 SP.. 0904
33 x D3 SP.. 0904
34 x D3 SP.. 1104
41 x D3 SP.. 1104
42 x D3 SP.. 1405
50 x D3 SP.. 1405

Face Milling

VFMRC

RCMT 10/12 Tip



VFMRC 5R-50-22-4T
VFMRC 5R-63-22-5T
VFMRC 6R-50-22-4T
VFMRC 6R-63-22-5T
VFMRC 6R-80-27-6T

VFM 45°

SN1206



VFM 45C-SN1206-
D050-A22-Z05H
VFM 45C-SN1206-
D200-C60-Z14

VFM 45°

SE.. 12T3..
R245-12T3..



VFM 45-SE12-D050-
A22-Z04-H
VFM 45-SE12-D125-
B10-Z11

VHFM

APMT 1604



VHFM-APMT 1604-D050/
63-A22-Z04-H
VHFM-APMT 1604-D080/
-A27-Z06-H

H 9! 90°

TP 16



VTSM CC06, D45x10,
W32 L120 Z06
VTSM CC09, D32x14,
W25 L100 Z04

VFM 45°

V CNCK



VFM 45-ON08-D063-
A22-Z05H
VFM 45-ON08-D200-
C60-Z12

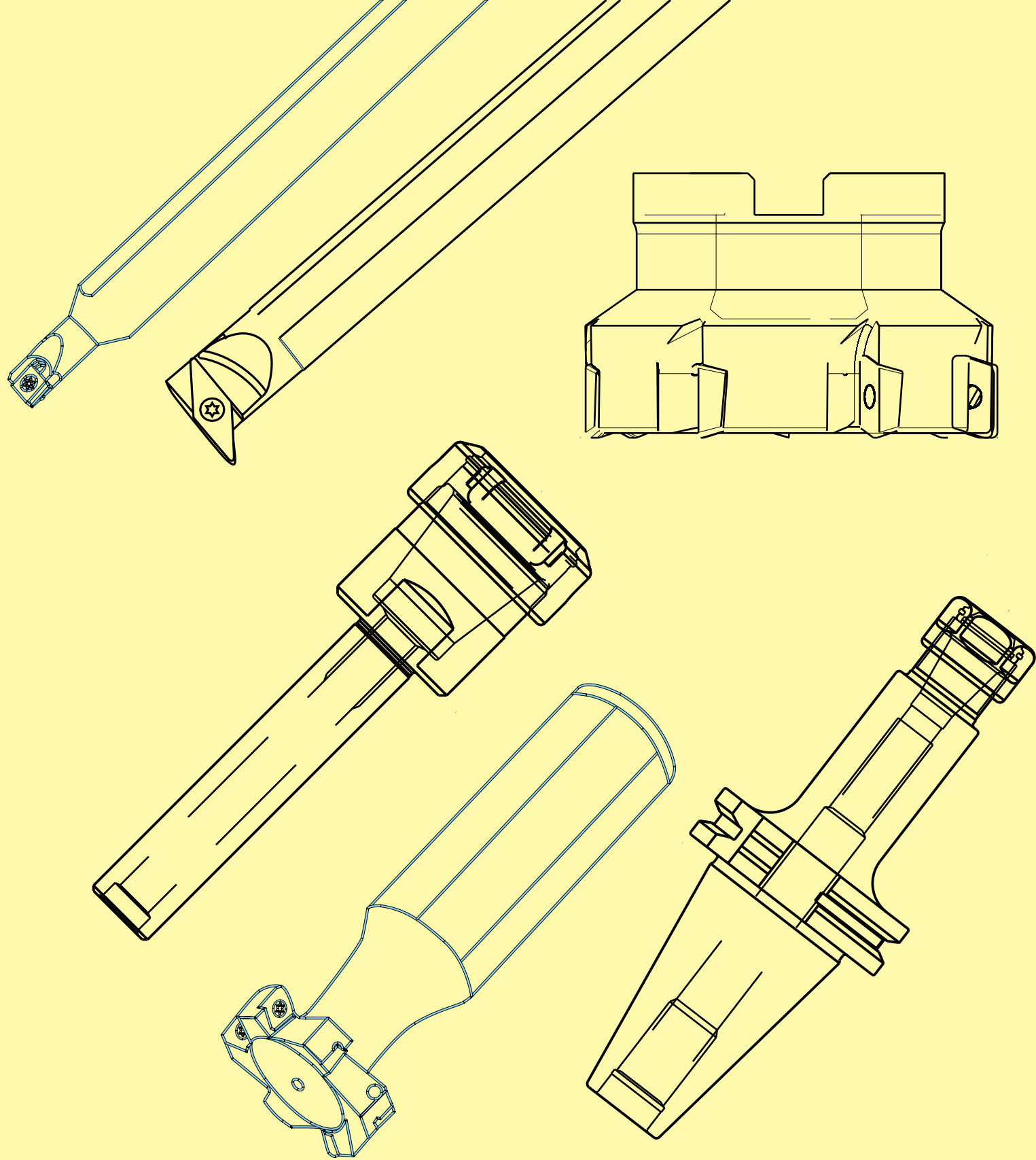

Manufactured By : NEW LAXMI ENGG. WORKS
An ISO 9001 : 2015 Certified Company

Regd. Office & Works : Plot No. 741, Sector-69, IMT Faridabad
Pin- 121004 (Haryana) INDIA

Contact Us : E-mail : vicuttools@gmail.com
Mobile : +91-9971363260, +91-9810676120



WWW.VICUTTOOLS.COM